



5200 W. CENTURY BLVD.
LOS ANGELES, CA 90045

**Smooth / Wood Grain / White Wood Grain
Rustic / Mahogany
Series Fiberglass Door
INSWING / OUTSWING
"IMPACT"**

GENERAL NOTES

1. This product has been evaluated and is in compliance with the 2010 Florida Building Code (FBC) structural requirements excluding the "High Velocity Hurricane Zone" (HVHZ).
2. Product anchors shall be as listed and spaced as shown on details. Anchor embedment to base material shall be beyond wall dressing or stucco.
3. When used in areas requiring wind borne debris protection this product complies with Section 1609.1.2 of the FBC and does not require an impact resistant covering. This product meets missile level "D" and includes Wind Zone 4 as defined in ASTM E1996 and Section 1609.1.2.4 of the FBC. The sidelite must be protected with an impact resistant covering that complies with Section 1609.1.2.
4. For 2x stud framing construction, anchoring of these units shall be the same as that shown for 2x buck masonry construction.
5. Site conditions that deviate from the details of this drawing require further engineering analysis by a licensed engineer or registered architect.

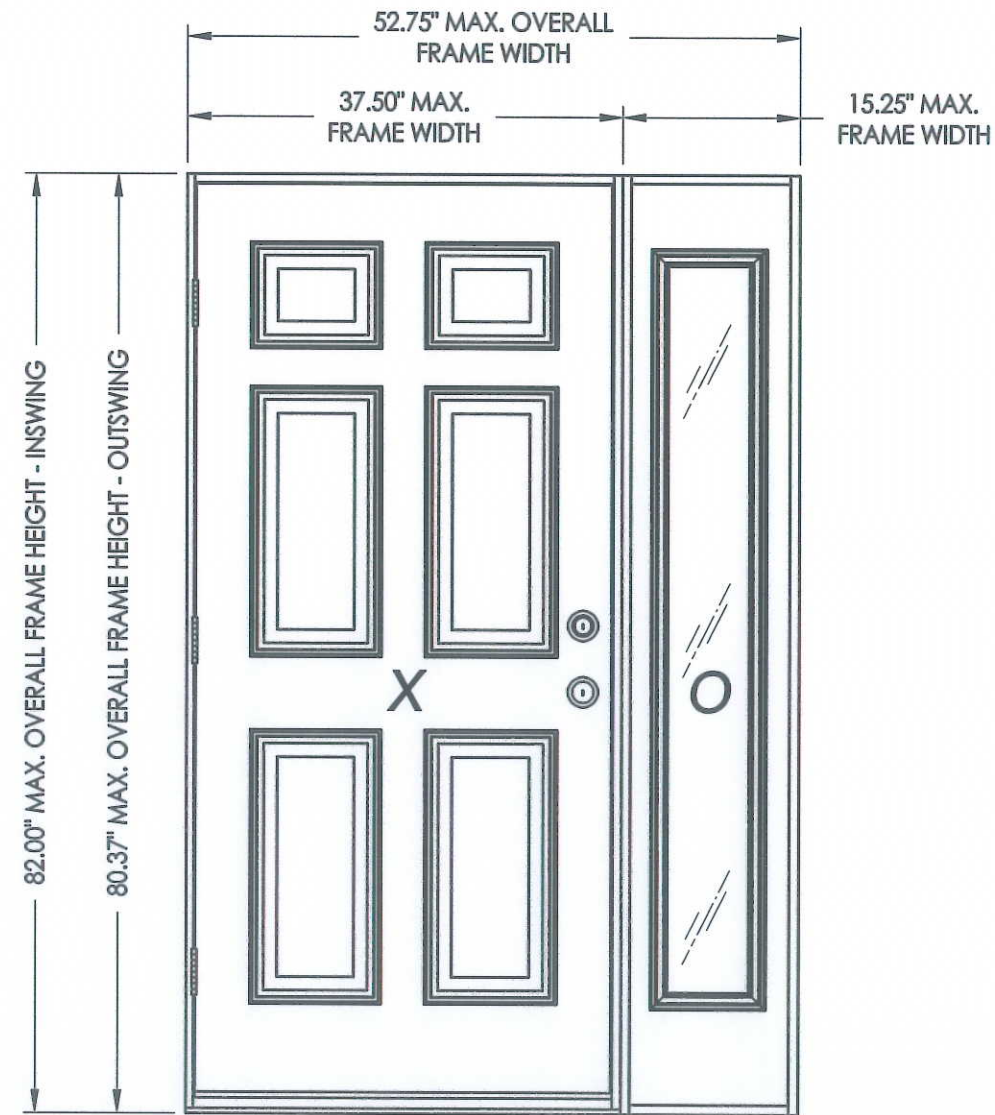

TABLE OF CONTENTS	
SHEET #	DESCRIPTION
1	Typical elevation, design pressures, & general notes
2	Door panel details
3	Sidelite panel details
4	Horizontal cross sections
5	Vertical cross sections
6	Vertical cross sections
7	Buck and frame anchoring - 2X buck masonry construction
8	Frame anchoring - 1X buck masonry construction
9	Bill of materials, glazing detail & components

SWING	OVERALL FRAME DIMENSION	SIDELITE D.L.O. DIMENSION	GLASS TYPE	DESIGN PRESSURE (PSF)	
				POSITIVE	NEGATIVE
INSWING	52.75" x 82.00"	7.00" x 63.00"	G1	+47.0	-47.0
OUTSWING	52.75" x 80.37"	7.00" x 63.00"			

Documents Prepared By:
RW BUILDING CONSULTANTS, INC.
P.O. Box 230 Vairico FL 33595
Phone No.: 813.659.9197
Florida Board of Professional Engineers
Certificate of Authorization No. 9813
LFS 2.17.12
Lyndon F. Schmidt, P.E. No. 43409

PRODUCT: PLASTPRO INC. FIBERGLASS DOOR
PART OR ASSEMBLY: TYPICAL ELEVATION, DESIGN PRESSURES & GENERAL NOTES

NO.	DATE	BY	REVISIONS

DATE: 02/16/12
SCALE: N.T.S.
DWG. BY: JK
CHK. BY: LFS
DRAWING NO.: FL-15213.2
SHEET 1 OF 9

R:\A - Projects\Project Folders\proj 1501 - 1600\PF 1587\D. RWBC Drawings\2010\FL-15213.1-8.dwg, 4.2

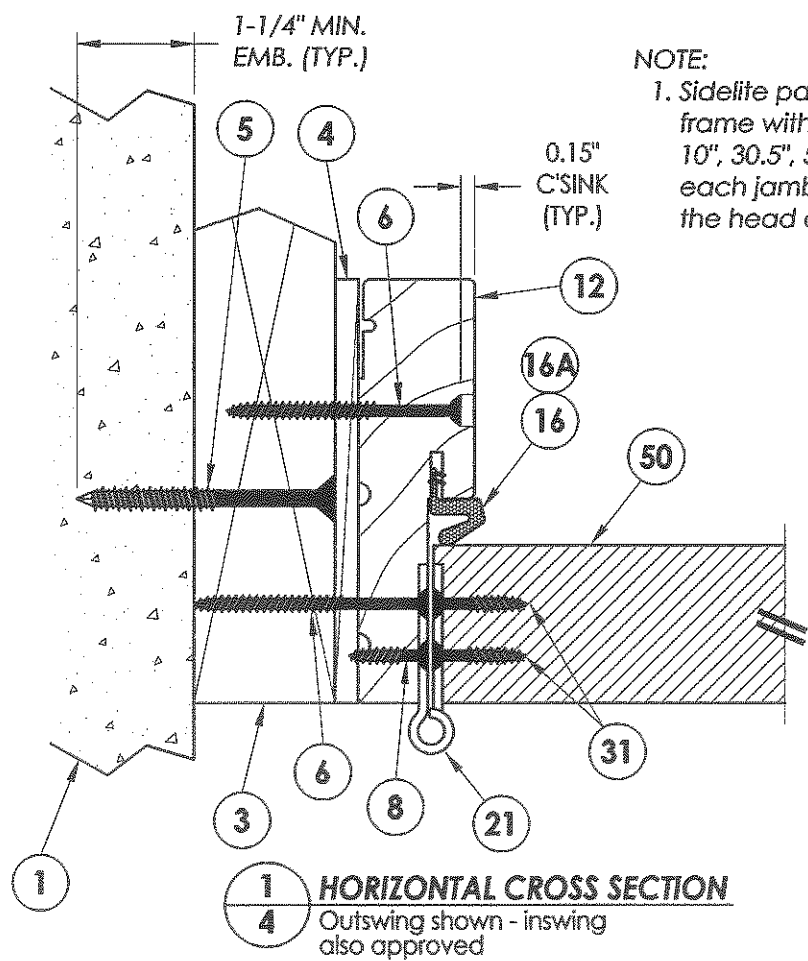
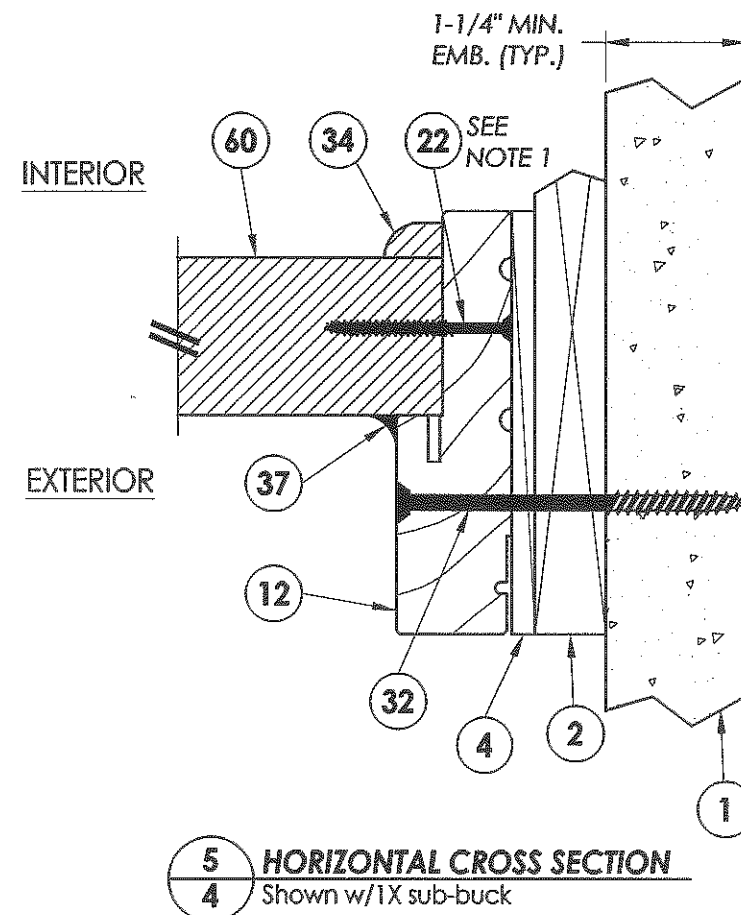
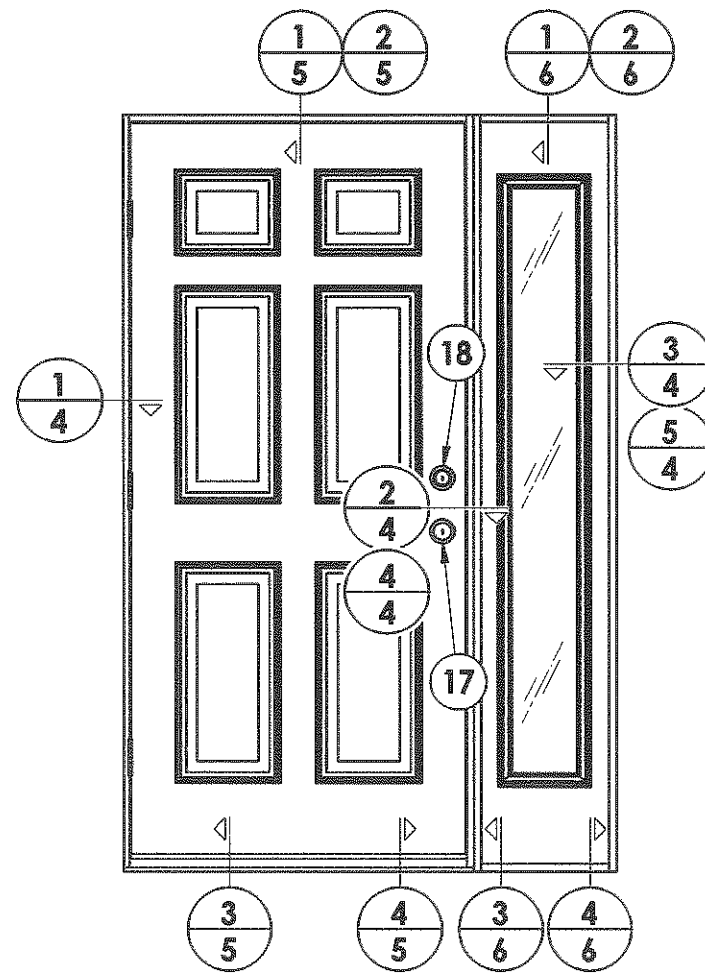
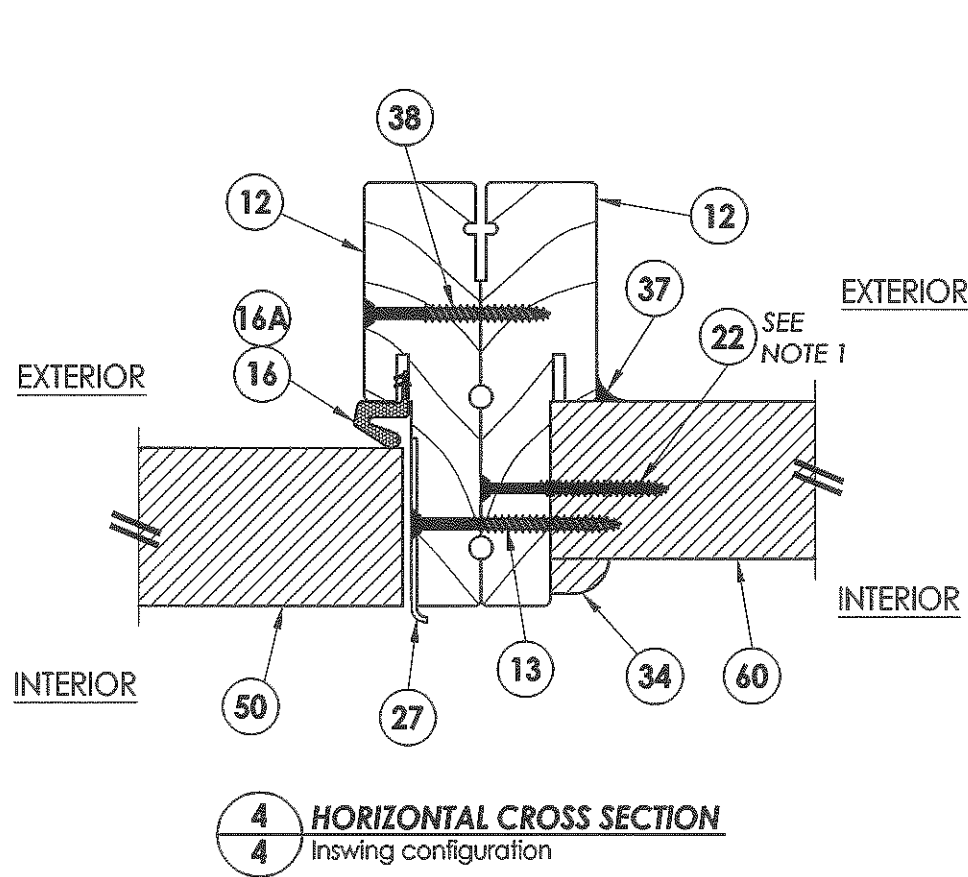

NOTE:
1. Sidelite panel secured to the sidelite frame with (4) of item #22 located 10", 30.5", 51" and 71.5" from top of each jamb and (2) of item #22 in the head and sill 3" from each end

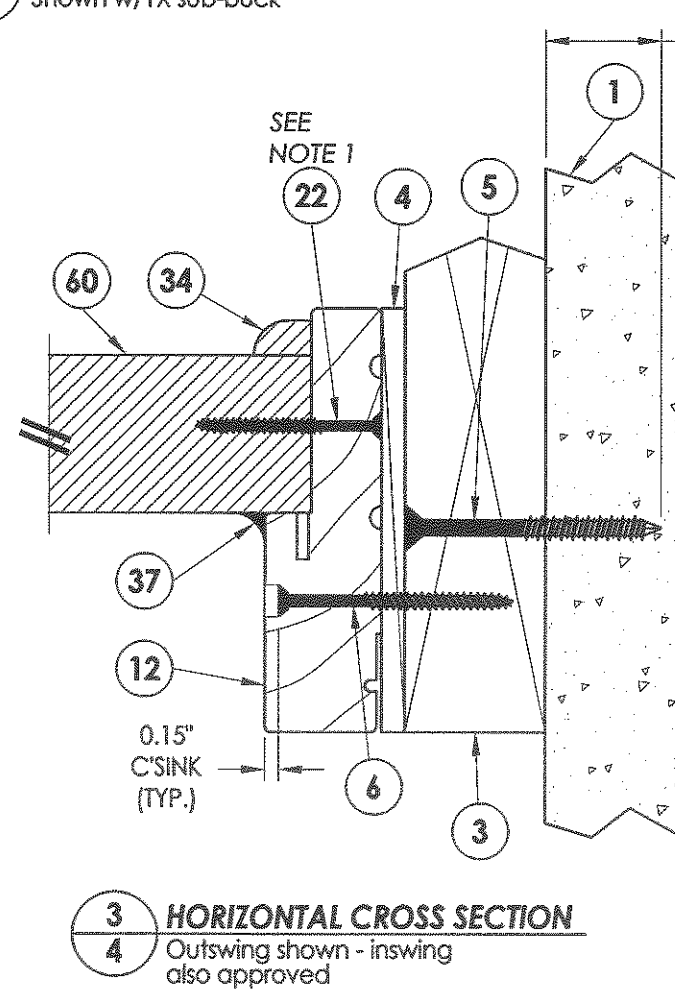
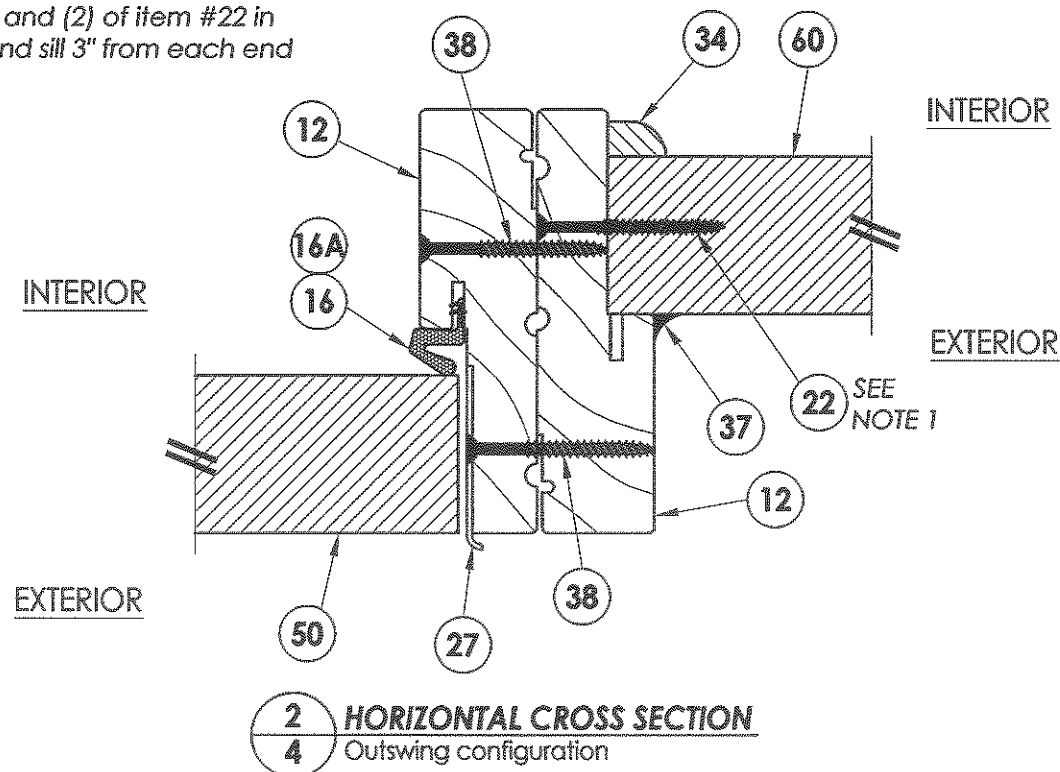

PRODUCT: PLASTIPRO INC. FIBERGLASS DOOR
PART OR ASSEMBLY: HORIZONTAL CROSS SECTIONS

NO.	DATE	BY	REVISIONS

DATE: 02/16/12
SCALE: N.T.S.
DWG. BY: JK
CHK. BY: LFS
DRAWING NO.: FL-15213.2
SHEET 4 OF 9

Documents Prepared By: RW BUILDING CONSULTANTS, INC.
P.O. Box 230 Valrico FL 33595
Phone No.: 813.659.9197
Florida Board of Professional Engineers
Certificate Of Authorization No. 9813
Lyndon F. Schmidt, P.E. No. 43408

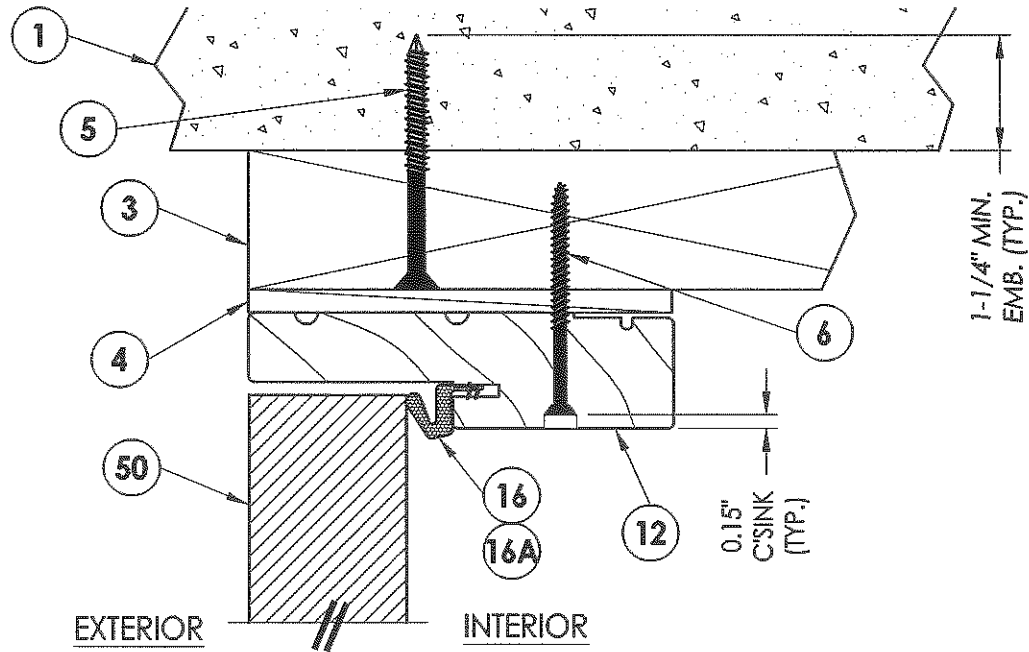

1 VERTICAL CROSS SECTION
5 Outswing shown - inswing also approved

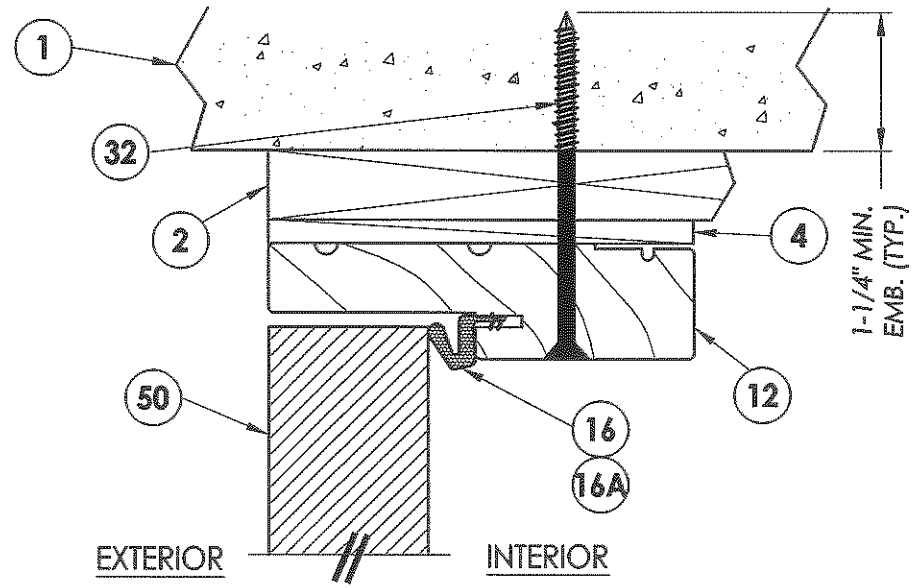

2 VERTICAL CROSS SECTION
5 Shown w/1X sub-buck

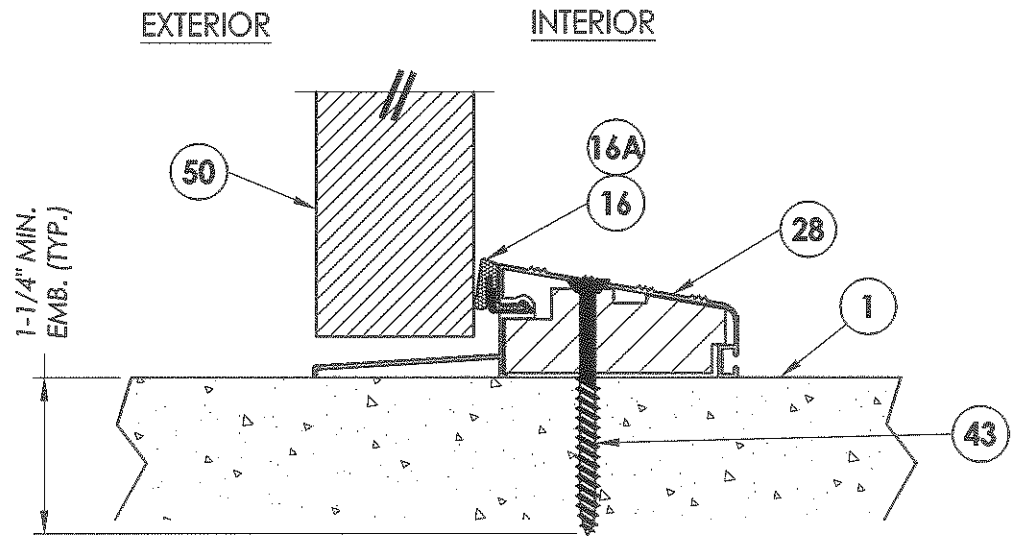

3 VERTICAL CROSS SECTION
5 Outswing configuration

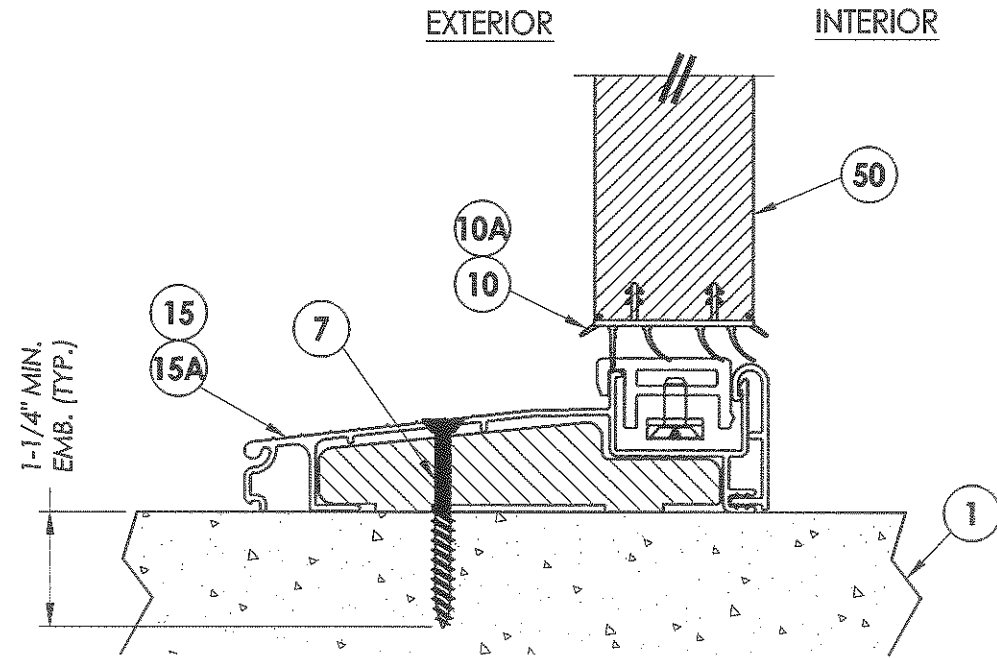

4 VERTICAL CROSS SECTION
5 Inswing configuration

Documents Prepared By:
RW BUILDING CONSULTANTS, INC.
 P.O. Box 230 Valrico FL, 33595
 Phone No.: 813.659.9197
 Florida Board of Professional Engineers
 Certificate Of Authorization No. 9813
 Lyndon F. Schmidt, P.E. No. 43409

PRODUCT:
 PLASTPRO INC.
 FIBERGLASS DOOR
 PART OR ASSEMBLY:
 VERTICAL CROSS SECTIONS

NO.	DATE	BY	REVISIONS

DATE: 02/16/12
 SCALE: N.T.S.
 DWG. BY: JK
 CHK. BY: LFS
 DRAWING NO.: FL-15213.2
 SHEET 5 OF 9

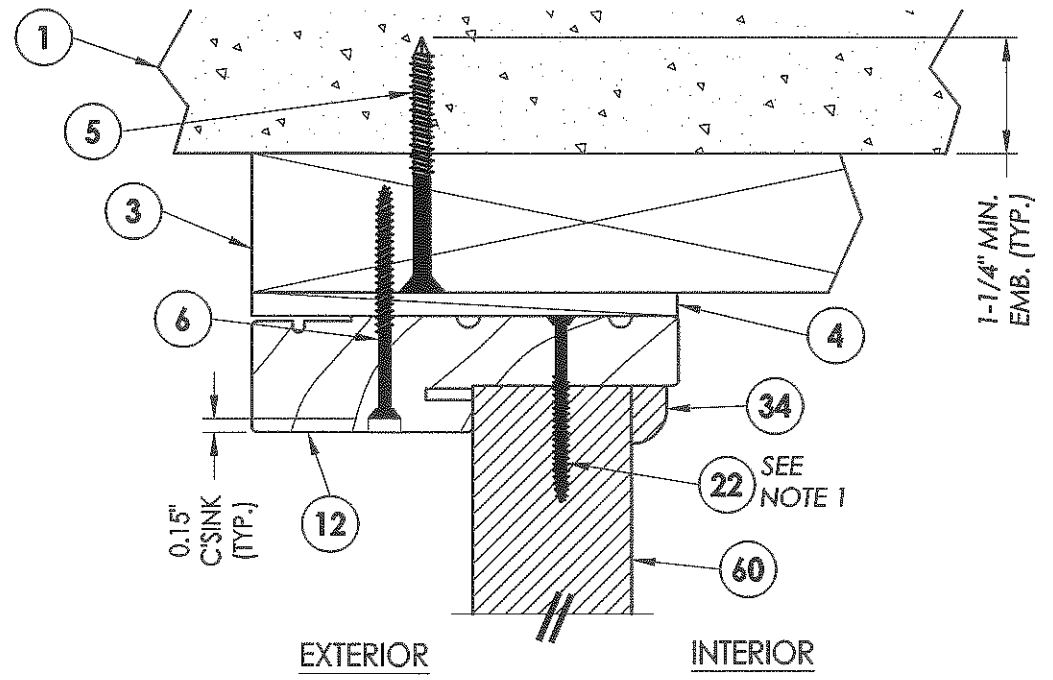

1 VERTICAL CROSS SECTION
6 Outswing shown - inswing also approved

NOTE:
 1. Sidelite panel secured to the sidelite frame with (4) of item #22 located 10", 30.5", 51" and 71.5" from top of each jamb and (2) of item #22 in the head and sill 3" from each end

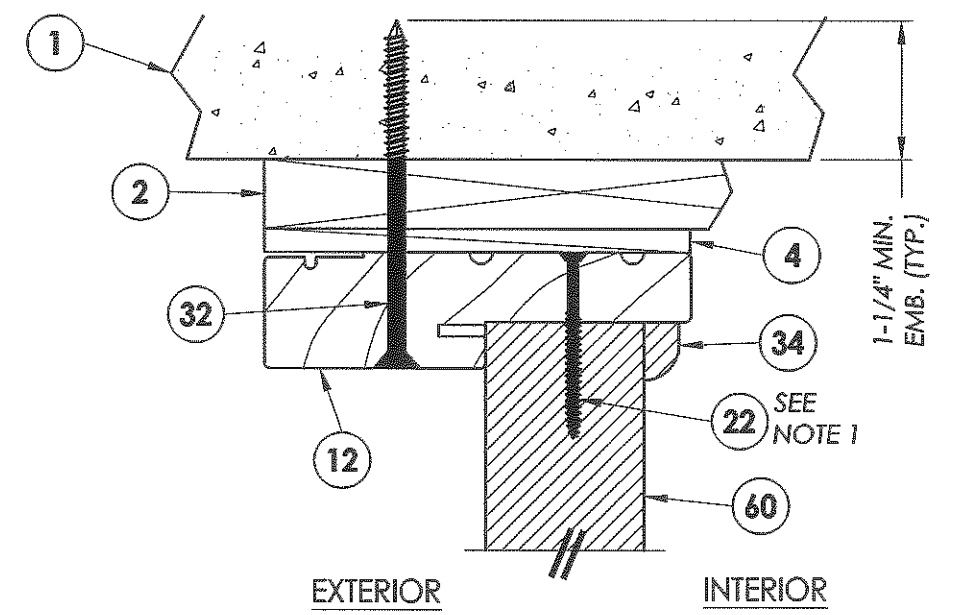

2 VERTICAL CROSS SECTION
6 Shown w/1X sub-buck

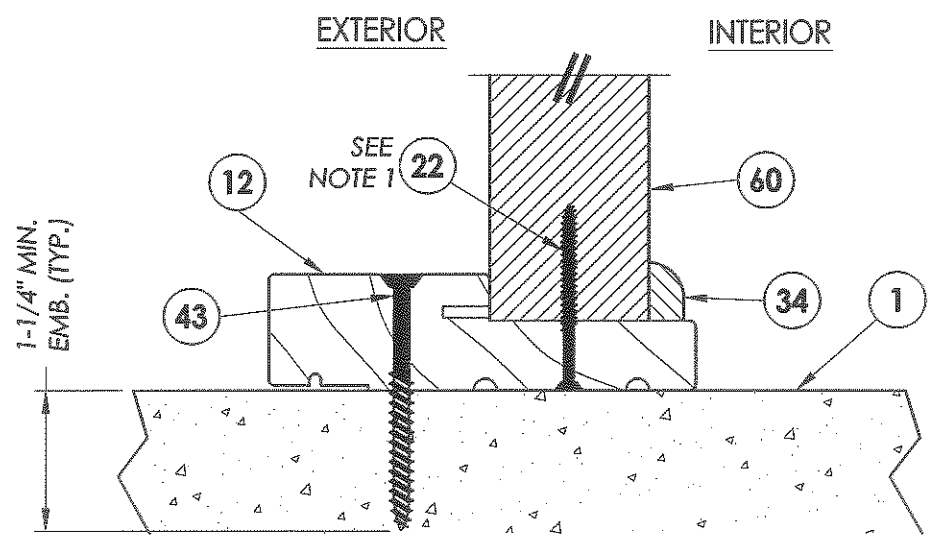

3 VERTICAL CROSS SECTION
6 Outswing configuration

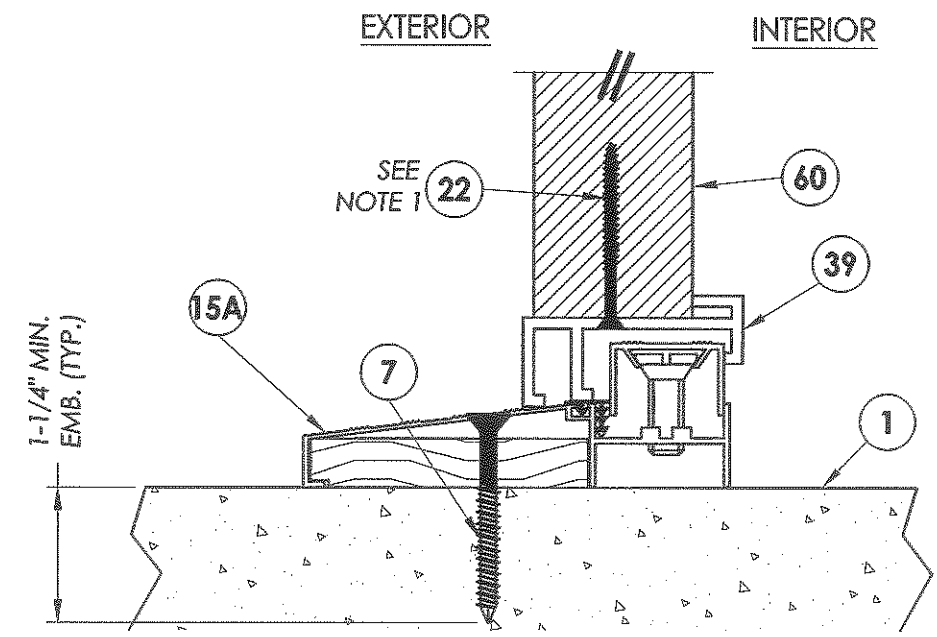

4 VERTICAL CROSS SECTION
6 Inswing configuration

Documents Prepared By:
RW BUILDING CONSULTANTS, INC.
 P.O. Box 230 Valrico FL 33595
 Phone No.: 813.659.9197
 Florida Board of Professional Engineers
 Certificate Of Authorization No. 9813
 Lyndon F. Schmidt, P.E. No. 43409

PRODUCT:
 PLASTIPRO INC.
 FIBERGLASS DOOR
 PART OR ASSEMBLY:
 VERTICAL CROSS SECTIONS

NO.	DATE	BY	REVISIONS

DATE: 02/16/12
 SCALE: N.T.S.
 DWG. BY: JK
 CHK. BY: LFS
 DRAWING NO.: FL-15213.2
 SHEET 6 OF 9

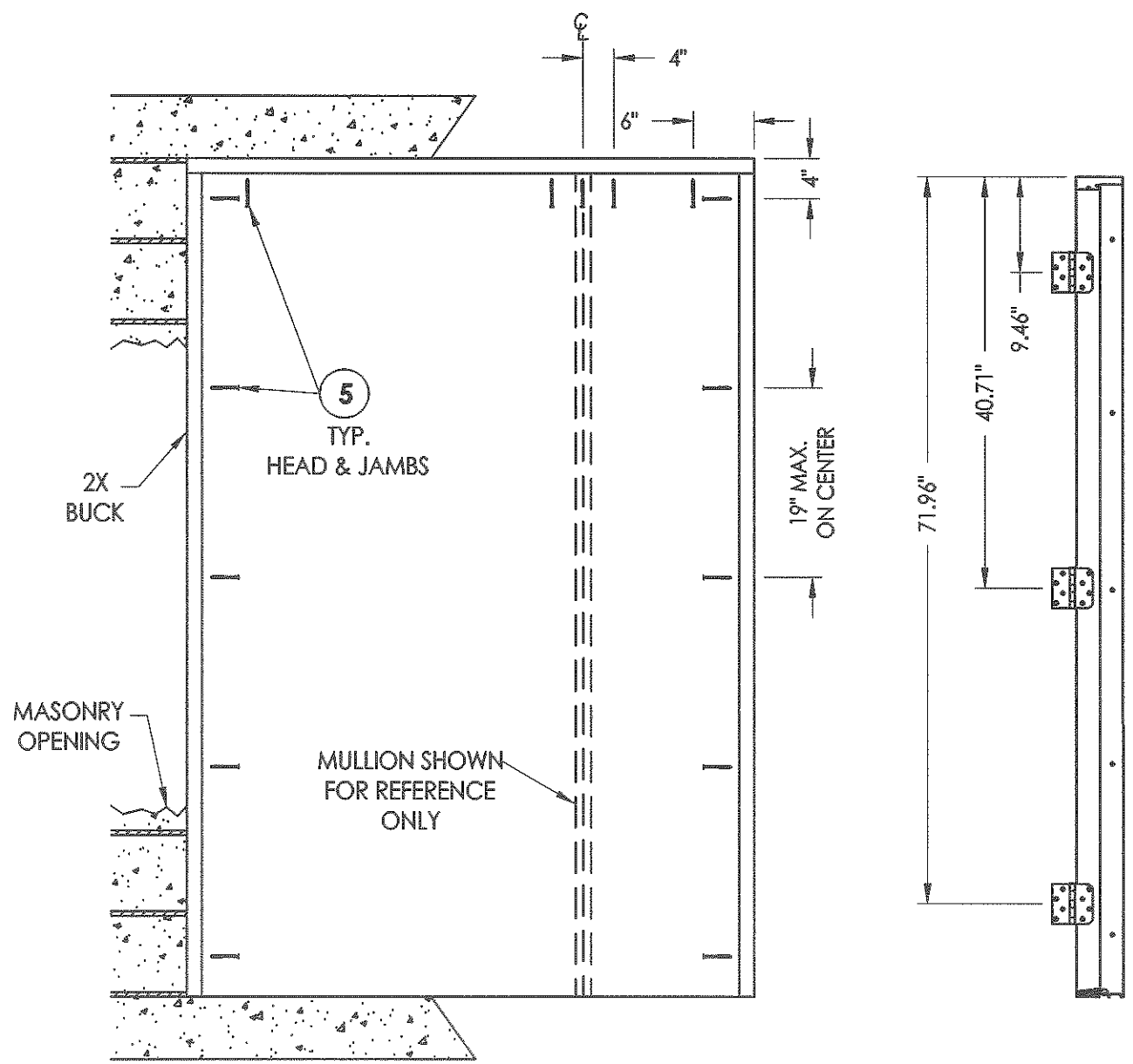

BUCK ANCHORING

HINGE JAMB

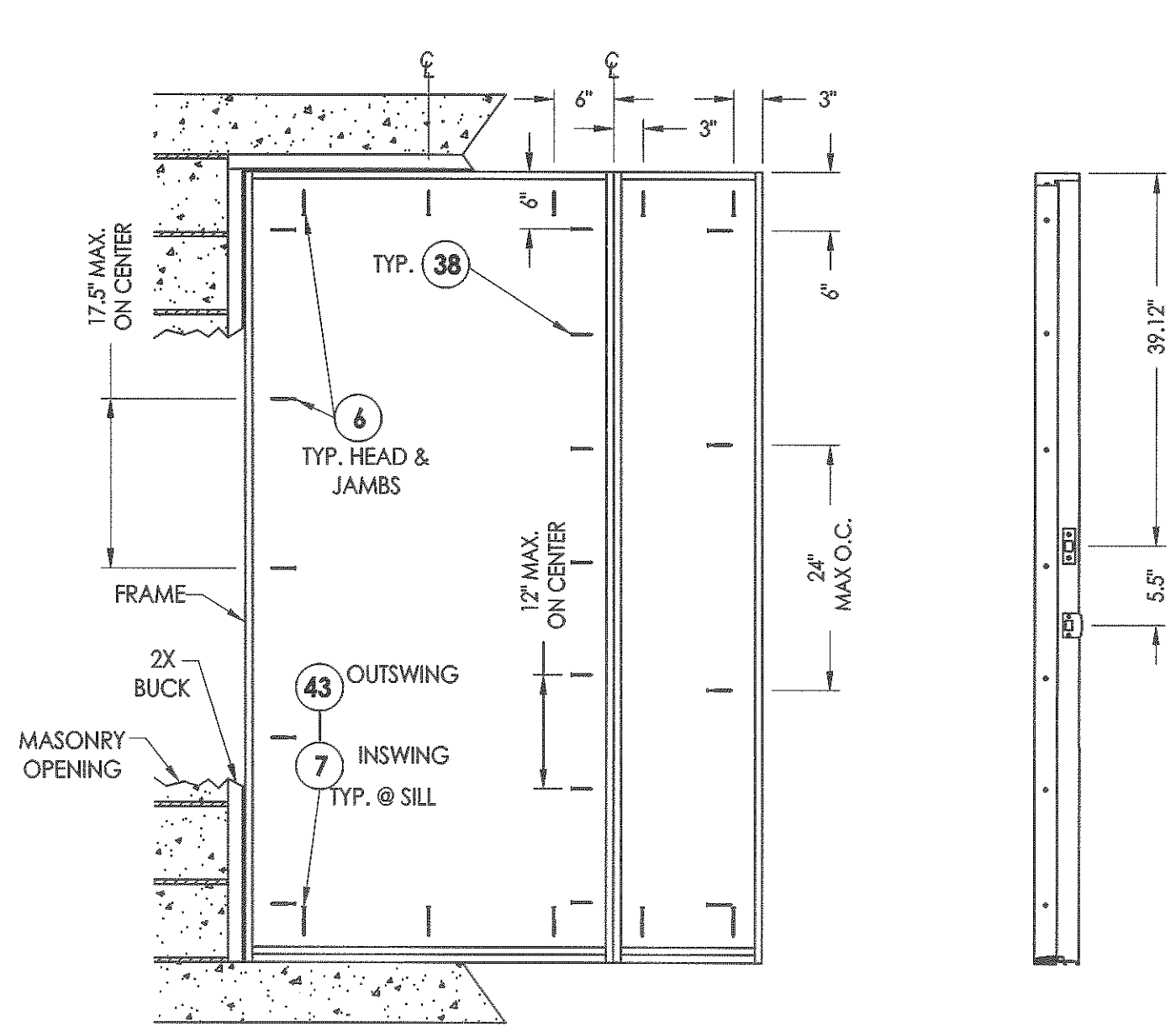

FRAME ANCHORING
Masonry 2X buck construction

STRIKE JAMB

CONCRETE ANCHOR NOTES:

1. Substitution of equal concrete anchors from a different supplier may have different edge distance and center distance requirements.
2. Concrete anchor locations at the corners may be adjusted to maintain the min. edge distance to mortar joints. If concrete anchor locations noted as "MAX. ON CENTER" must be adjusted to maintain the min. edge distance to mortar joints, additional concrete anchors may be required to ensure the "MAX. ON CENTER" dimensions are not exceeded.
3. Concrete anchor table:

ANCHOR TYPE	ANCHOR SIZE	MIN. EMBEDMENT	MIN. CLEARANCE TO MASONRY EDGE	MIN. CLEARANCE TO ADJACENT ANCHOR
ITW	1/4"	1-1/4"	2-1/2"	3"
ELCO	1/4"	1-1/4"	1"	4"

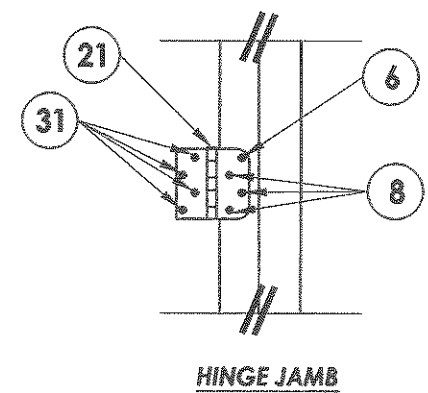

HINGE JAMB

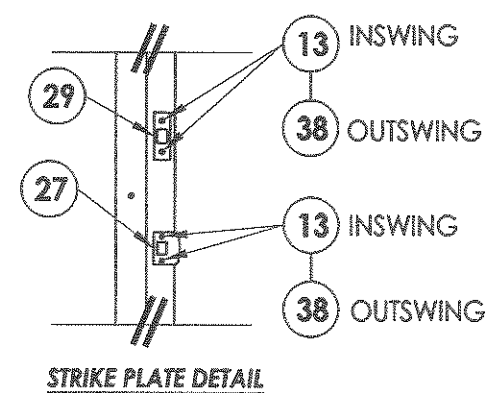

STRIKE PLATE DETAIL

Documents Prepared By: **RW** BUILDING CONSULTANTS, INC.
P.O. Box 230 Valrico FL 33595
Phone No.: 813.659.9197
Florida Board of Professional Engineers
Certificate of Authorization, No. 9813
Lyndon F. Schmidt, P.E. No. 43409

PRODUCT: PLASTPRO INC. FIBERGLASS DOOR
PART OR ASSEMBLY: BUCK & FRAME ANCHORING
2X BUCK MASONRY CONSTRUCTION

NO.	DATE	BY	REVISIONS

DATE: 02/16/12
SCALE: N.T.S.
DWG. BY: JK
CHK. BY: LFS
DRAWING NO.: FL-15213.2
SHEET 7 OF 9

© 2012 R.W. BUILDING CONSULTANTS INC.

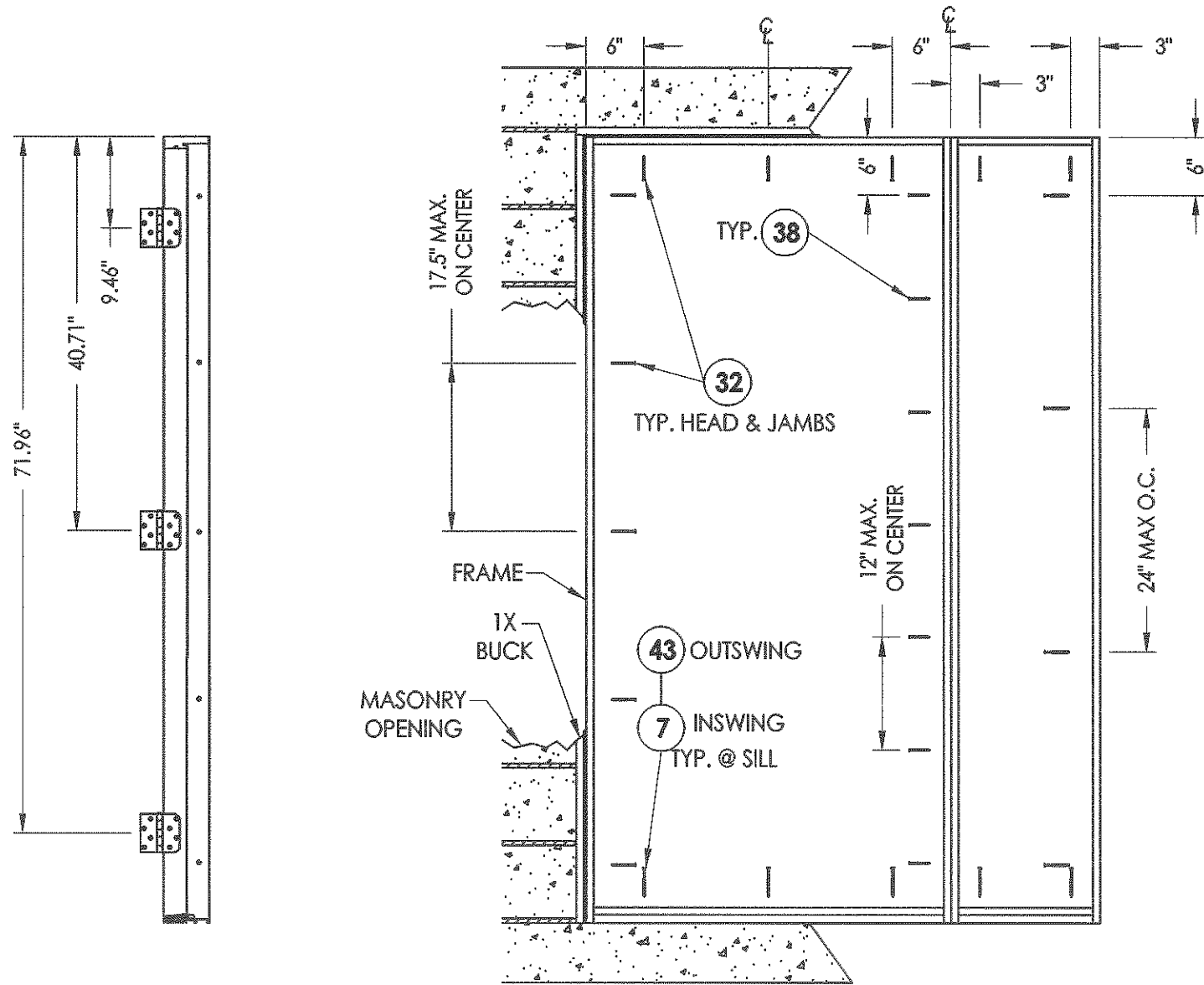

HINGE JAMB

FRAME ANCHORING
Masonry 1X buck construction

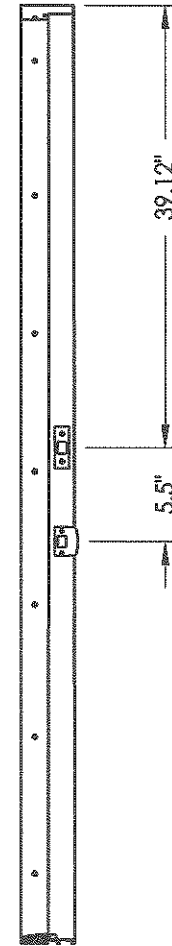

STRIKE JAMB

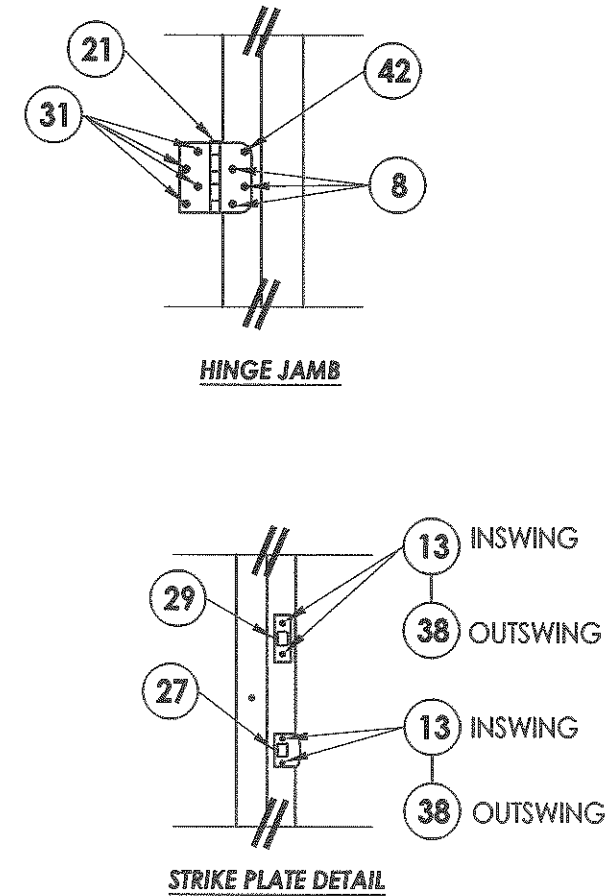

STRIKE PLATE DETAIL

CONCRETE ANCHOR NOTES:

1. Substitution of equal concrete anchors from a different supplier may have different edge distance and center distance requirements.
2. Concrete anchor locations at the corners may be adjusted to maintain the min. edge distance to mortar joints. If concrete anchor locations noted as "MAX. ON CENTER" must be adjusted to maintain the min. edge distance to mortar joints, additional concrete anchors may be required to ensure the "MAX. ON CENTER" dimensions are not exceeded.
3. Concrete anchor table:

ANCHOR TYPE	ANCHOR SIZE	MIN. EMBEDMENT	MIN. CLEARANCE TO MASONRY EDGE	MIN. CLEARANCE TO ADJACENT ANCHOR
ITW	1/4"	1-1/4"	2-1/2"	3"

PRODUCT: PLASTPRO INC. FIBERGLASS DOOR
PART OR ASSEMBLY: 1X BUCK MASONRY CONSTRUCTION

NO	DATE	BY	REVISIONS

DATE: 02/16/12
SCALE: N.T.S.
DWG. BY: JK
CHK. BY: LFS
DRAWING NO.: FL-15213.2
SHEET 8 OF 9

Documents Prepared By:
RW BUILDING CONSULTANTS, INC.
P.O. Box 230 Vairico FL 33595
Phone No.: 813.659.9197
Florida Board of Professional Engineers
Certificate Of Authorization No. 9813
Lyndon F. Schmidt, P.E. No. 43409
2.17.12

R:\A - Projects\Project Folders\proj_1501 - 1600\PF_1587\DWG Drawings\2010\FL-15213.1-8.dwg, 9.2

BILL OF MATERIALS		
ITEM	DESCRIPTION	MATERIAL
1	MASONRY - 3,192 PSI MIN. CONCRETE CONFORMING TO ACI 301 OR HOLLOW BLOCK CONFORMING TO ASTM C90	CONCRETE
2	1X BUCK SG >= 0.55	WOOD
3	2X BUCK SG >= 0.55	WOOD
4	1/4" MAX. SHIM SPACE	-
5	1/4" X 2-3/4" PFH ELCO OR ITW CONCRETE SCREW	STEEL
6	#10 X 2-1/2" PFH WOOD SCREW	STEEL
7	1/4" X 2-1/4" PFH ITW CONCRETE SCREW	STEEL
8	#9 X 3/4" PFH WOOD SCREW	STEEL
9	DOOR SKIN (MIN. 0.075" THICK)	FIBERGLASS
10	INSWING VINYL DOOR BOTTOM SWEEP BY ENDURA	VINYL
10A	VINYL DOOR BOTTOM SWEEP #3628 BY HOLM IND.	VINYL
11	REINFORCEMENT WOOD FOR LOCK	WOOD
12	FINGER JOINTED PINE FRAME, HEAD & HINGE JAMBS	WOOD
13	#9 X 2-1/4" PFH WOOD SCREW	STEEL
14	BOTTOM RAIL	CELLULAR PVC
15	INSWING ADJUSTABLE THRESHOLD BY ENDURA	ALUM. / WOOD
15A	INSWING ADJUSTABLE ALUMINUM THRESHOLD BY DLP	ALUM. / WOOD
16	FORCE 5 WEATHER STRIPPING BY ENDURA	FOAM
16A	COMPRESSION WEATHER STRIP QLON 650 BY SCHLEGEL	FOAM
17	KWIKSET KEYED ENTRY - SIGNATURE SERIES	STEEL
18	KWIKSET DEADBOLT - SIGNATURE SERIES (780)	STEEL
19	CONTINUOUS SIDELITE STILE REINF.	WOOD
20	POLYURETHANE FOAM BY NANYA	POLYURETHANE
21	4" X 4" BUTT HINGE	STEEL
22	#8 X 2" PFH WOOD SCREW	STEEL
24	HINGE & LATCH STILE	CELLULAR PVC
25	TOP RAIL	CELLULAR PVC
26	SIDELITE STILE	CELLULAR PVC
27	STRIKE PLATE	STEEL
28	OUTSWING BUMP THRESHOLD	ALUM. / WOOD
29	DEADBOLT STRIKE PLATE	STEEL
30	SNAP IN LITE FRAME	ABS
31	#9 X 1" PFH WOOD SCREW	STEEL
32	1/4" X 3-3/4" PFH ITW CONCRETE SCREW	STEEL
33	SIDELITE TOP & BOTTOM RAIL	CELLULAR PVC
34	SHOE MOULD 5/8" X 3/8"	WOOD
35	GLAZING COMPOUND	SILICONE
36	GLAZING SPACER	ALUM.
37	SEALANT	SILICONE
38	#9 X 2" PFH WOOD SCREW	STEEL
39	SIDELITE SPACER	PVC
40	HINGE & LATCH STILE REINFORCEMENT	LVL
42	1/4" X 3-1/4" PFH ITW CONCRETE SCREW	STEEL
43	1/4" X 2-3/4" PFH ITW CONCRETE SCREW	STEEL
50	DOOR PANEL - SEE DOOR PANEL DETAIL SHEET FOR CONSTRUCTION DETAILS	-
60	SIDELITE PANEL - SEE DOOR PANEL DETAIL SHEET 3	-

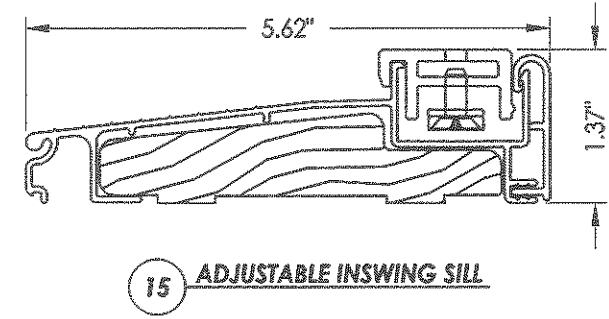
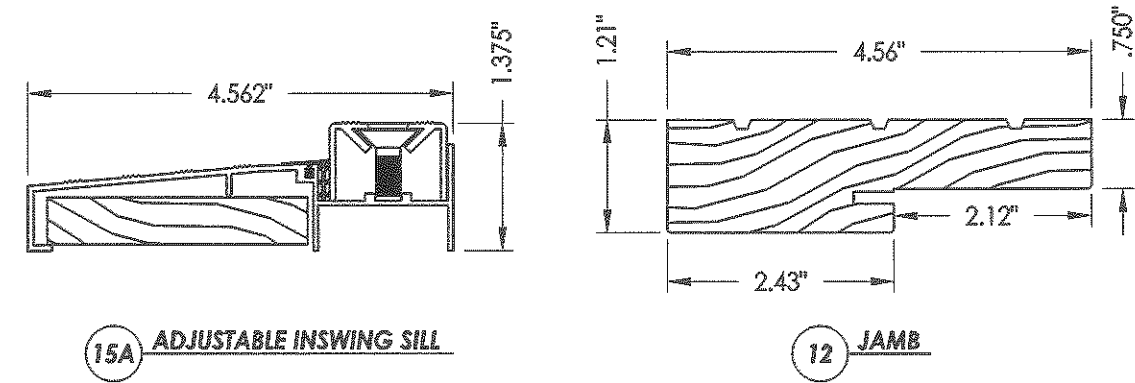
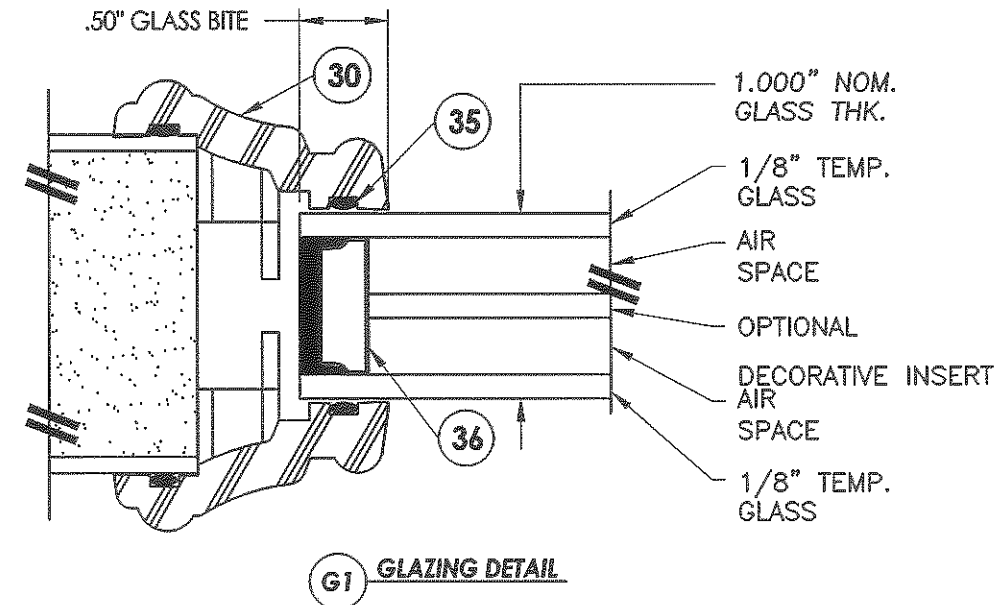
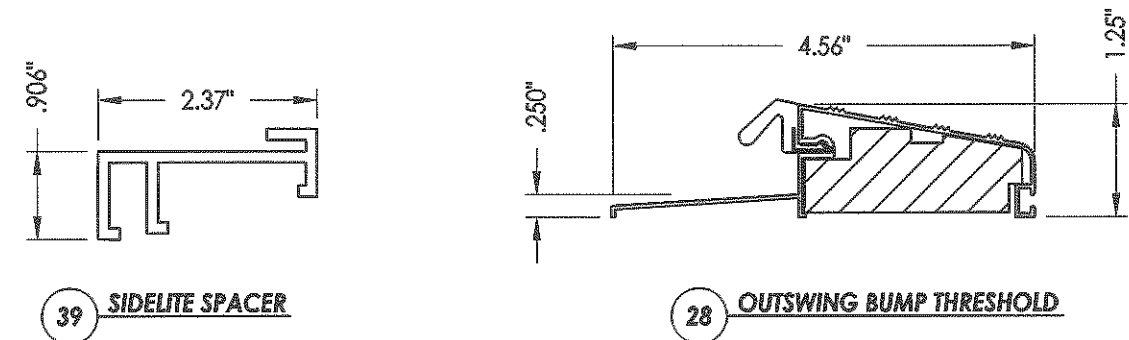

Documents Prepared By: **RW BUILDING CONSULTANTS, INC.**
P.O. Box 230 Valrico FL 33595
Phone No.: 813.659.9197
Florida Board of Professional Engineers
Certificate Of Authorization No. 9813
Lyndon F. Schmidt, P.E. No. 43409

PRODUCT: **PLASTPRO INC. FIBERGLASS DOOR**
PART OR ASSEMBLY: **BILL OF MATERIALS, GLAZING DETAIL & COMPONENTS**

NO.	DATE	BY	REVISIONS

DATE: 02/16/12
SCALE: N.T.S.
DWG. BY: JK
CHK. BY: LFS
DRAWING NO.: FL-15213.2
SHEET 9 OF 9

© 2012 R.W. BUILDING CONSULTANTS INC.